

OWNER'S MANUAL

Dual Adjustable Pulley Machine

Model #: N820 DP

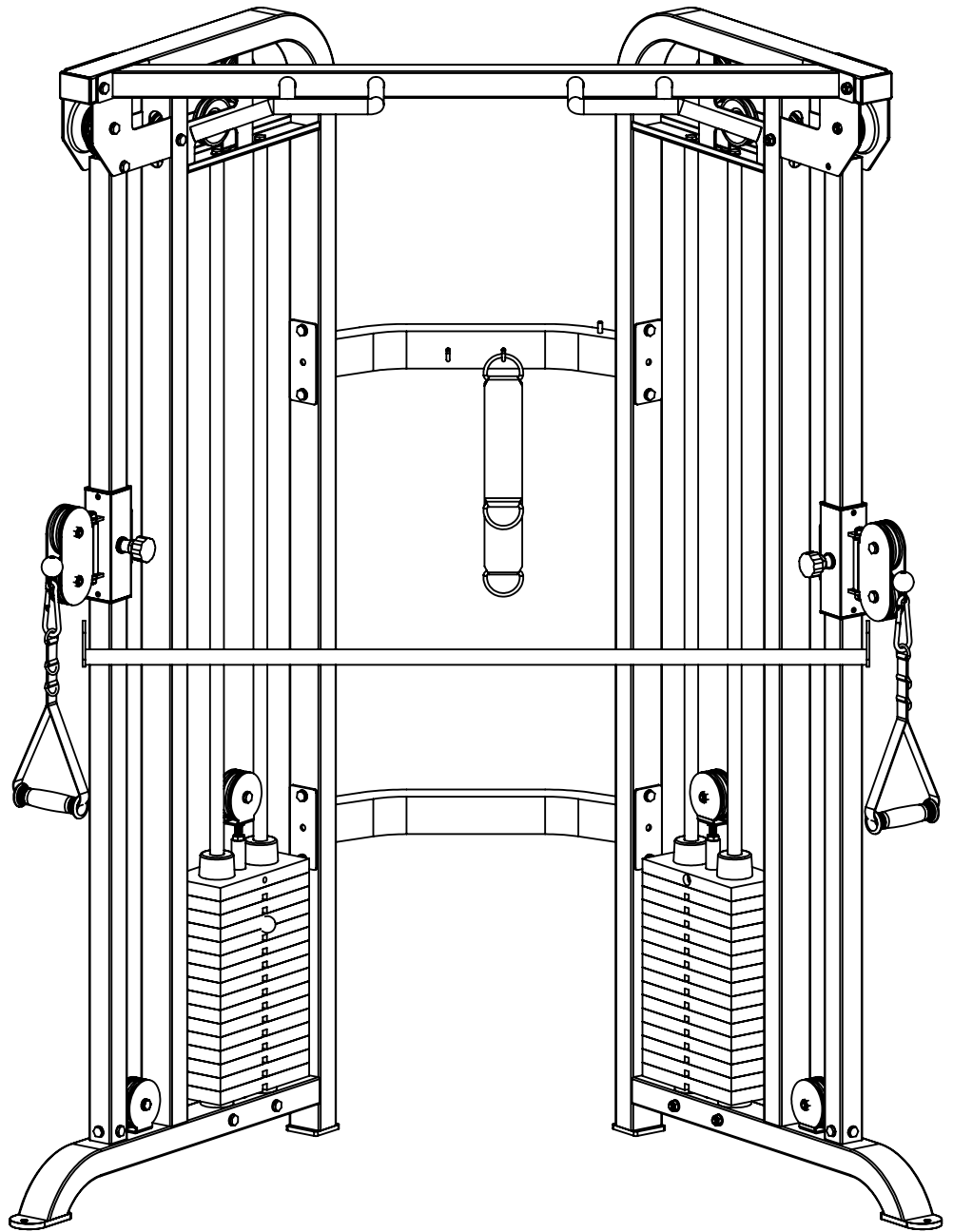

Caution: Read all precautions and instructions in this manual before using this equipment. Save this manual for future reference.

Assembly Instructions

Contents

Contents	1
Before You Begin	2
Parts List & Assembly Steps	3-9
Parts & Hardware List	10-11

Assembly Instructions

Before Your Begin

This exercise equipment is built for optimum safety. Be sure to read the entire manual before you assemble or operate your equipment. Please note the following safety precautions:

1. Keep children and pets away from the equipment at all times. Do not leave children unattended in the same room with the equipment.
2. Only one person at a time should use the equipment.
3. If the user experiences dizziness, nausea, chest pain, or any other abnormal symptoms STOP the workout at once.
CONSULT A PHYSICIAN IMMEDIATELY.
4. Position the equipment on a clear, level surface. DO NOT use the bench near water or outdoors.
5. Keep hands away from all moving parts.
6. Always wear appropriate workout clothing when exercising. DO NOT wear robes or other clothing that could become caught in the equipment.
7. Use the equipment only for its intended use as described in this manual. DO NOT use attachments not recommended by the manufacturer.
8. Before using the equipment, always do stretching exercises to properly warm up.
9. Never operate the equipment if the equipment is not functioning properly.

Tools Required

Tools Required : Allen Wrench Set / Socket Wrench Set
Adjustable Wrench / Crescent Wrench
Rubber Mallet / Tape Measure

ASSEMBLY REQUIRES AT LEAST TWO PERSONS

WARNING: This Product Is Rated for Home Use Only!

Using this product in a commercial setting will void all warranties
and can result in serious injury or death!

Assembly Instructions

STEP 1 - Parts & Hardware List

Part#	Description	Qty	Remark
1	Main Upright Frame	2	
2	Squat Bar	1	
3	Right Slide Frame	1	
4	Left Slide Frame	1	
5	Front Top Cross Frame	1	
6	Guide Rod	4	
13	Right Slider	1	
14	Left Slider	1	
15	Double Pulley Bracket	2	Pre-assembled
16	Pop Pin	2	
17	Upper Cross Frame	1	
18	Lower Cross Frame	1	
19	Pulley Bracket Bushing	2	Pre-assembled
20	Axle	2	Pre-assembled
21	Upper Cross Frame Plate	2	
22	Left Handle	1	
23	Right Handle	1	
25	Guide Sleeve	4	Pre-assembled
29	F50x70mm Inner Cap	2	Pre-assembled
30	Strap Hook	2	
H10-2	M10x20mm Hex Head Bolt	10	
H10-13	M10x75mm Hex Head Bolt	8	
H10-15	M10x85mm Hex Head Bolt	6	
H10-17	M10x95mm Hex Head Bolt	4	
W6	M6 Washer	2	
W10	M10 Washer	50	
N6	M6 Nut	2	
N10	M10 Nut	22	

Assembly Instructions

STEP 1

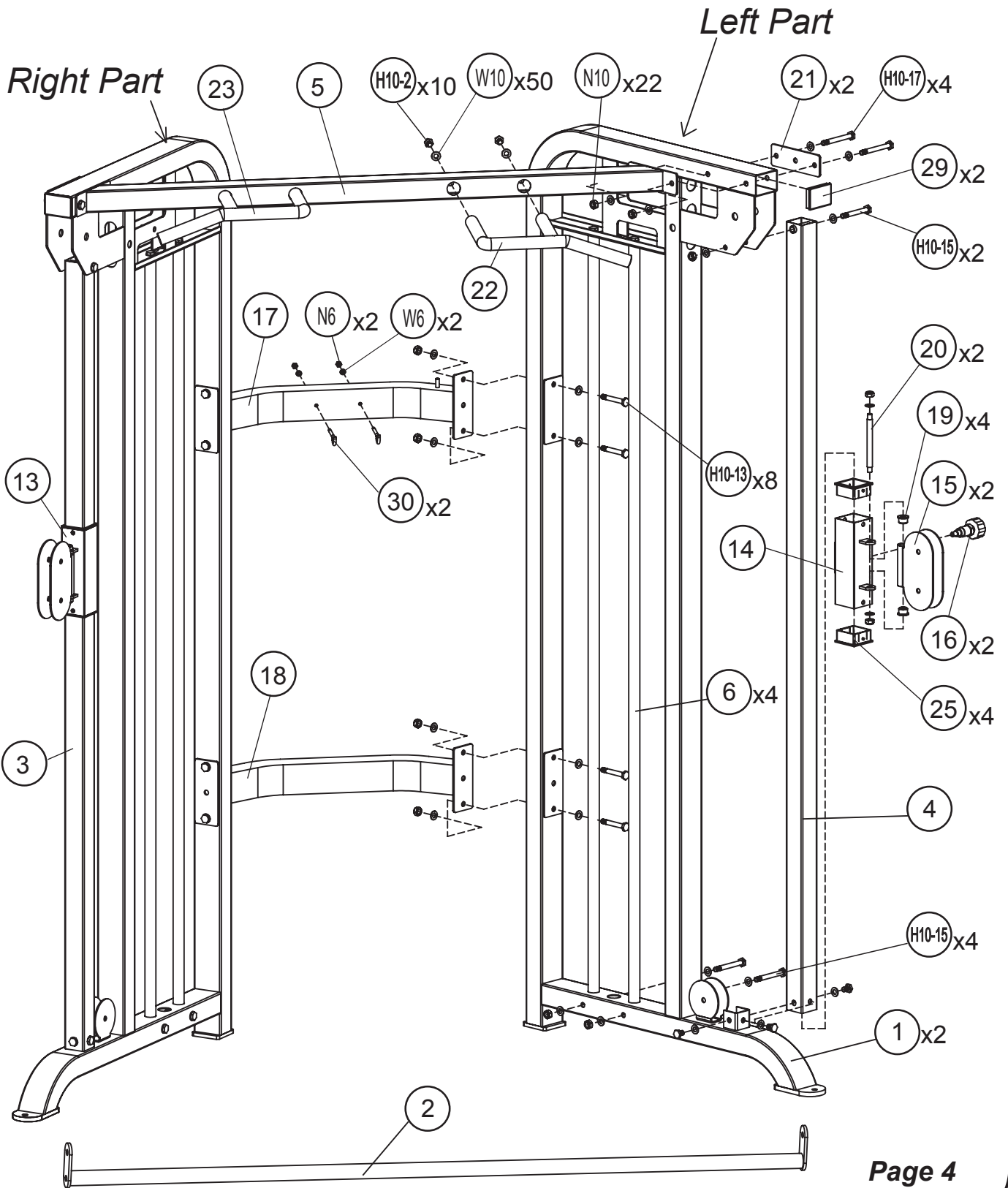

Assembly Instructions

STEP 2 - Parts & Hardware List

Part#	Description	Qty	Remark
7	Rubber Bumper	4	
8	Weight Stack Plate	30	
9	Weight Select Pin	2	
10	Weight Selector	2	
11	Weight Top Plate	2	
12	Single Pulley Bracket	2	
H10-2	M10x20mm Hex Head Bolt	4	
H10-11	M10x65mm Hex Head Bolt	2	Pre-assembled
W10	M10 Washer	4	
N10	M10 Nut	2	Pre-assembled
N12	M12 Nut	2	Pre-assembled

Assembly Instructions

STEP 2

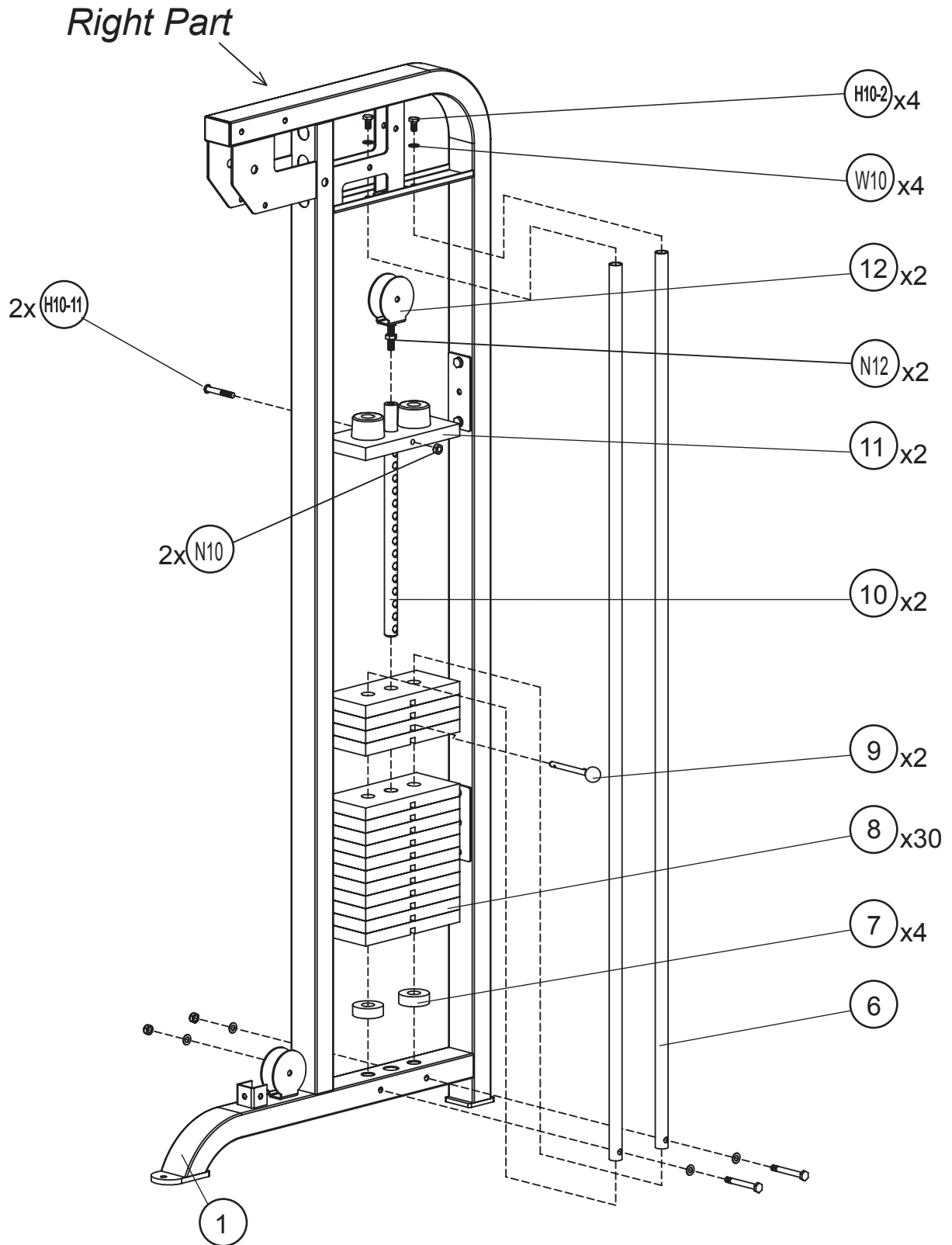

Note: Assemble the Left Part In the Same Way.

Assembly Instructions

STEP 3 - Parts & Hardware List

Part#	Description	Qty	Remark
24	Pulley Bushing	8	
26	Cable	2	
27	Clip	2	
28	Strap Handle	2	
31	Small Pulley	14	
32	Big Pulley	2	
33	Ankle Strap	1	
H10-8	M10x50mm Hex Head Bolt	12	
H10-15	M10x85mm Hex Head Bolt	4	
W10	M10 Washer	24	
N10	M10 Nut	16	

Assembly Instructions

STEP 3

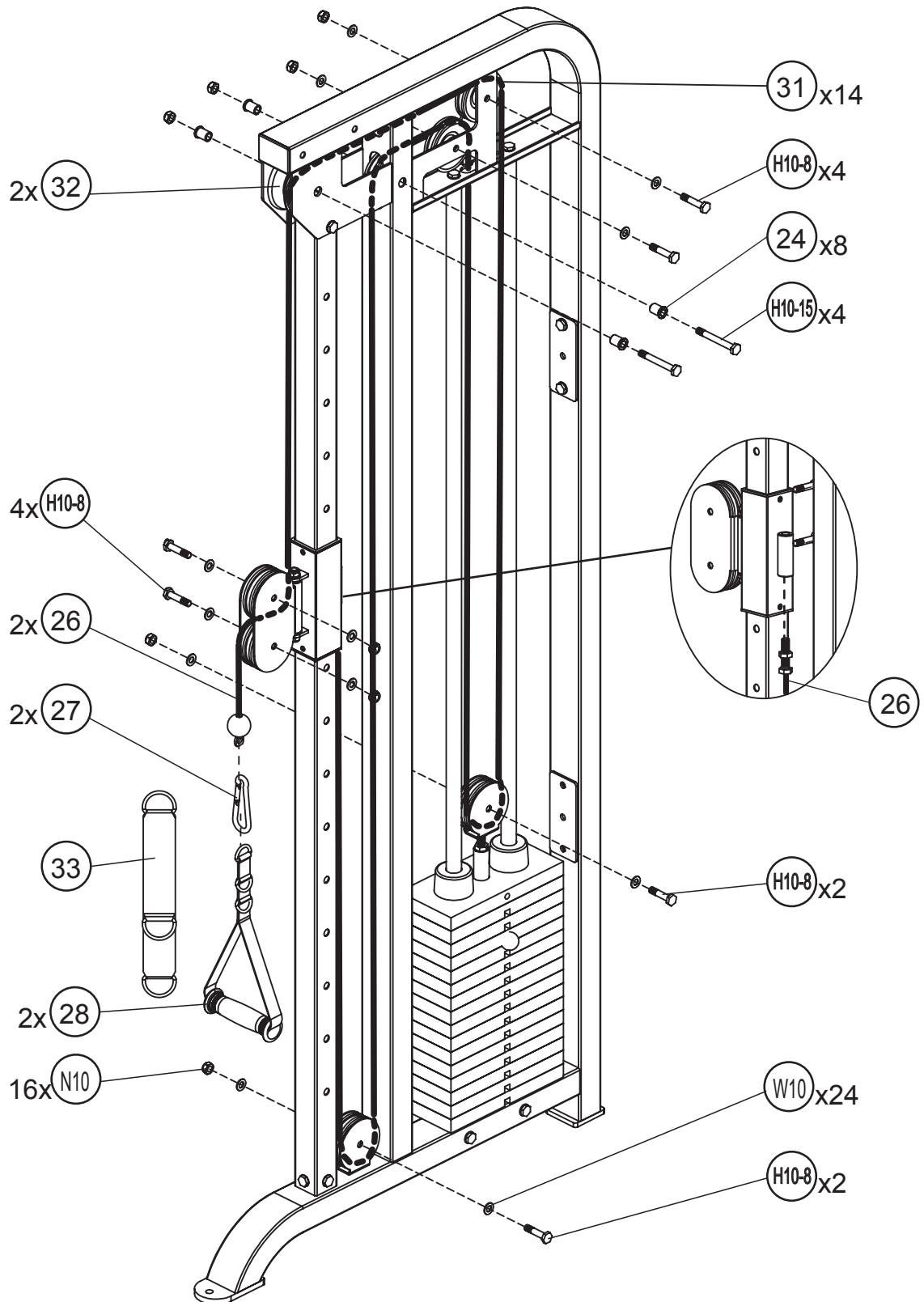

Assembly Instructions

Cable Loop Diagram

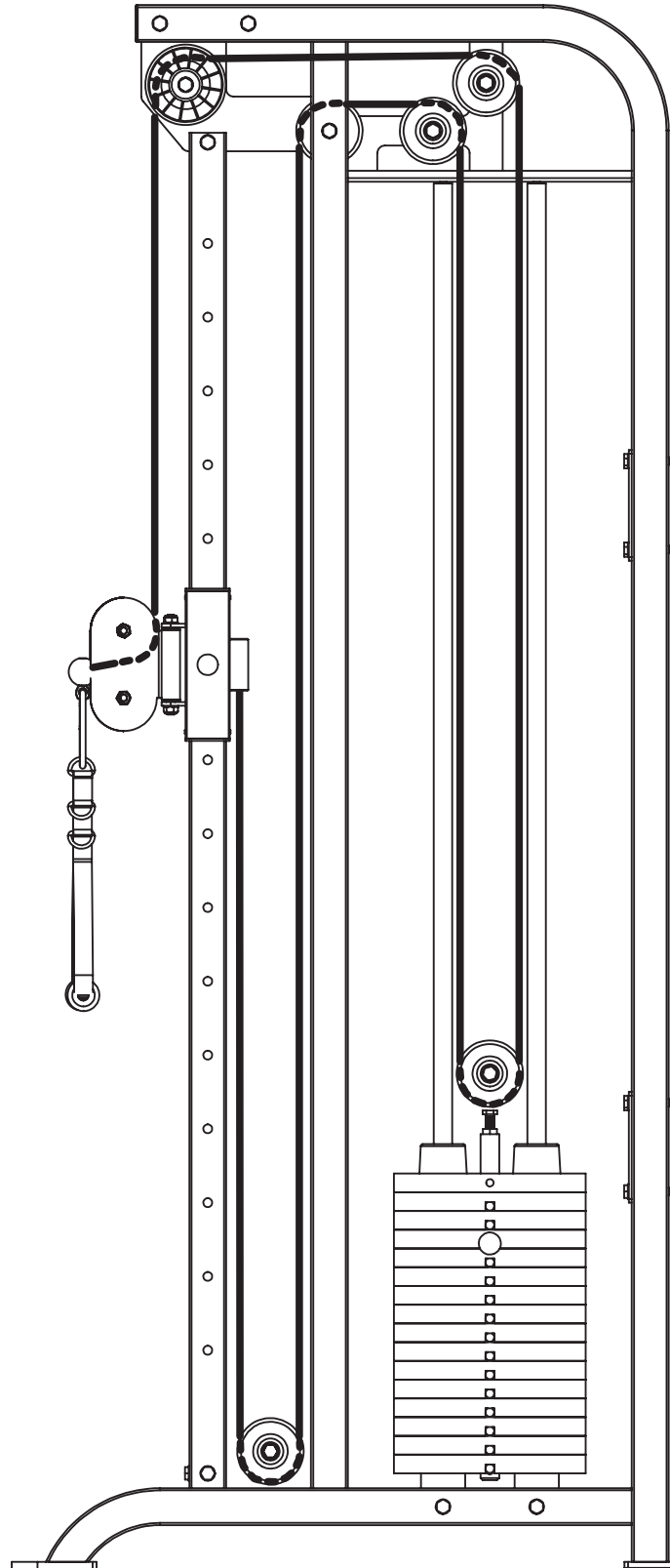

Assembly Instructions

Parts & Hardware List

Part#	Description	Qty	Remark
1	Main Upright Frame	2	
2	Squat Bar	1	
3	Right Slide Frame	1	
4	Left Slide Frame	1	
5	Front Top Cross Frame	1	
6	Guide Rod	4	
7	Rubber Bumper	4	
8	Weight Stack Plate	30	
9	Weight Select Pin	2	
10	Weight Selector	2	
11	Weight Top Plate	2	
12	Single Pulley Bracket	2	
13	Right Slider	1	
14	Left Slider	1	
15	Double Pulley Bracket	2	Pre-assembled
16	Pop Pin	2	
17	Upper Cross Frame	1	
18	Lower Cross Frame	1	
19	Pulley Bracket Bushing	2	Pre-assembled
20	Axle	2	Pre-assembled
21	Upper Cross Frame Plate	2	
22	Left Handle	1	
23	Right Handle	1	
24	Pulley Bushing	8	
25	Guide Sleeve	4	Pre-assembled
26	Cable	2	
27	Clip	2	
28	Strap Handle	2	
29	F50x70mm Inner Cap	2	Pre-assembled
30	Strap Hook	2	
31	Small Pulley	14	
32	Big Pulley	2	
33	Ankle Strap	1	

Assembly Instructions
Parts & Hardware List

Part#	Description	Qty	Remark
H10-2	M10x20mm Hex Head Bolt	14	
H10-8	M10x50mm Hex Head Bolt	12	
H10-11	M10x65mm Hex Head Bolt	2	
H10-13	M10x75mm Hex Head Bolt	8	
H10-15	M10x85mm Hex Head Bolt	10	
H10-17	M10x95mm Hex Head Bolt	4	
W6	M6 Washer	2	
W10	M10 Washer	78	
N6	M6 Nut	2	
N10	M10 Nut	40	
N12	M12 Nut	2	