

BODYWORX

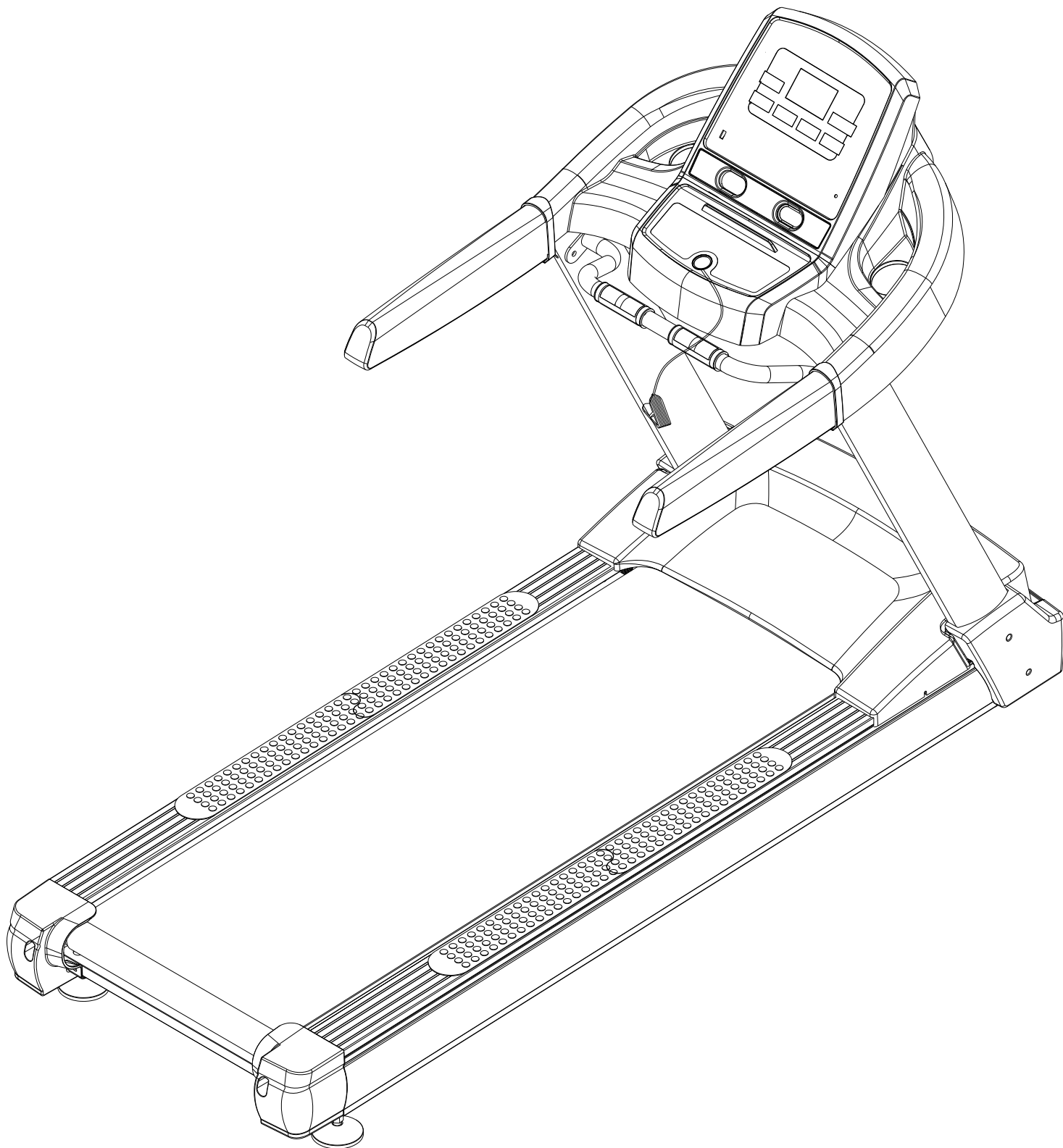

BODYWORX JT8500 TREADMILL

Model No: JT8500



Retain this owner's manual for future reference. Read and follow all instructions in this owner's manual.



Warranty Registration Form

Congratulations on purchasing your product, we at GPI believe that our product range is of the highest quality and represents great value for money.

We back our product range up with our industry leading warranty.

Please see below for the step by step instructions on how to register your product warranty online.



Step 1 Visit our Website

Go to the GPI Sports website: www.gpisports.com.au/warranty



Step 2 Enter Purchase Information

Enter all purchase information including the serial number and proof of purchase which can be uploaded from this page



Step 3 Call Our Toll Free Number

If a warranty service request is required on your product please call the toll free number - **1800 005 770**

CONTENT

| | |
|-------------------------------------|-------|
| CONTENT | 1 |
| IMPORTANT SAFETY PRECAUTIONS | 3-4 |
| ASSEMBLY INSTRUCTIONS | 5-7 |
| GROUNDING METHODS | 8 |
| OPERATION GUIDE | 9-16 |
| SAFETY EXERCISES | 17 |
| WARM-UP EXERCISES | 18 |
| MAINTENANCE INSTRUCTIONS | 19 |
| BELT ADJUSTMENT | 20 |
| EXPLODED DRAWING | 21 |
| PARTS LIST | 22-23 |
| ERROR CODE AND SIGNIFICANCE | 24 |

The main technical parameters

| | |
|---------------------------------------|---|
| Input supply voltage: 240V | Working temperature: 0-40 °C |
| Speed range: 0.8-22.0 KH/M | Incline range:15 levels Motor incline |
| Max. user weight: 180kg | Distance display range: 0.00-99.9km |
| Calories display range: 000-999 | Time display range: 00: 00-99: 59 (min : sec) |
| Heart rate range: 50-200 (time / min) | Running surface: 560*1540mm |
| Product size: 2080*850*1520 mm | |

Product Overview

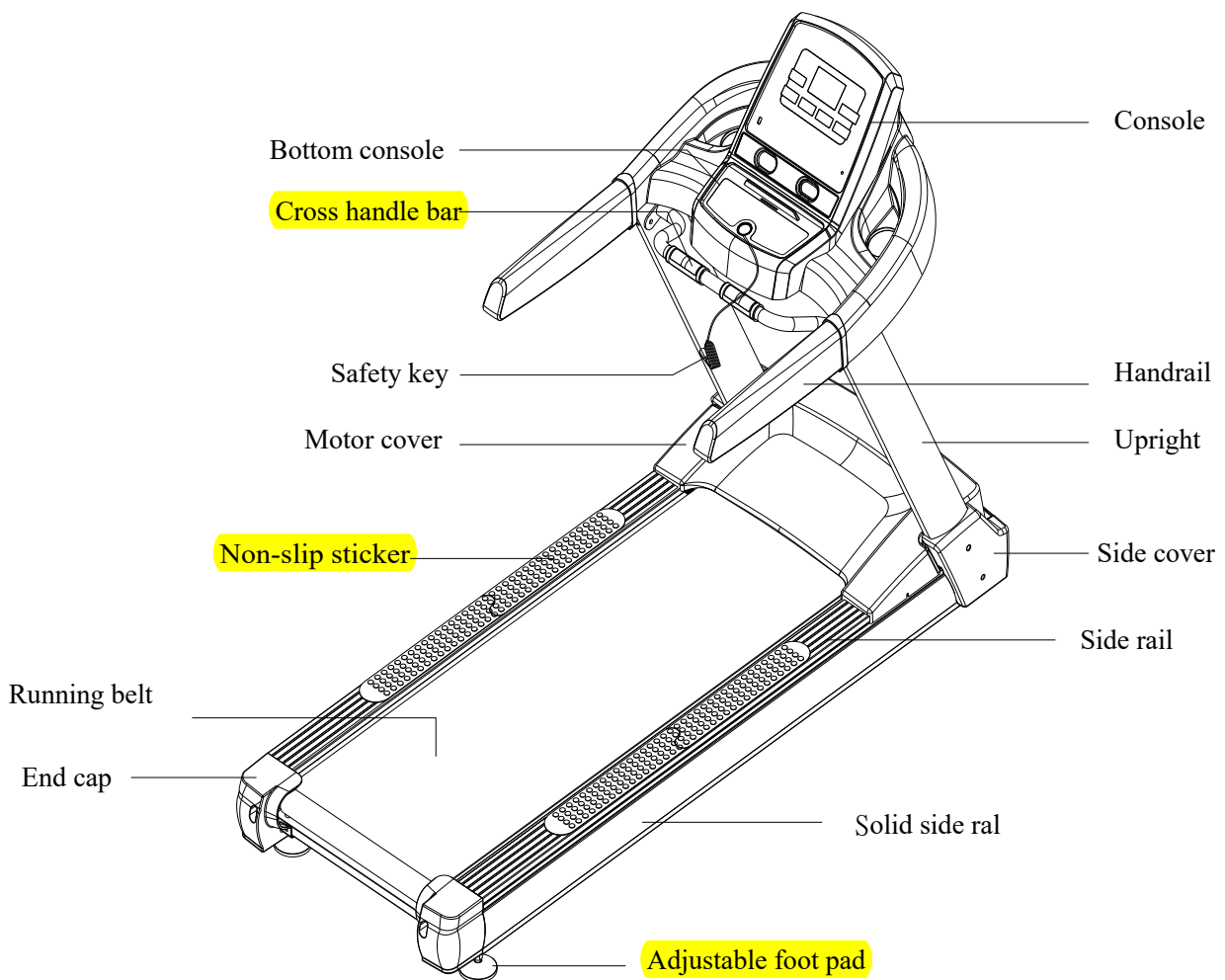

IMPORTANT SAFETY PRECAUTIONS





WARNING: Before starting any exercise program, consult with your physician or health professional, especially a person who is above 35 years old or has some health problems. We take no responsibility for any troubles or injuries due to the reasons above. Don't power on until you finish assembling the treadmill and covering the protected top of the motor.

ATTENTIONS:

1. When using this treadmill, keep attaching the safety pull pin rope to your clothes or belt.
2. Do not plug anything into any parts of this equipment as it may cause damage and a serious safety risk.
3. Position the treadmill on a clear, level surface. Do not place the treadmill on thick carpet as it may interfere with proper ventilation.
Also, do not place the treadmill near water or outdoors.
4. Never start the treadmill while you are standing on the walking belt. After turning the power on and adjusting the speed control, there may be a pause before the walking belt begins to move, always stand on the foot rails on the sides of the frame until the belt is moving.
5. Wear appropriate clothing when exercising on the treadmill. Do not wear long, loose fitting clothing that could become caught in the treadmill. Always wear running or aerobic shoes with rubber soles.
6. Keep small children or pets away from the treadmill during operation.
7. Do not exercise for 40 minutes after a meal.
8. This treadmill is designed and intended for use by adults. Any use by people less than adult age needs to be under strict supervision and at the risk of the user and supervisor.
9. Always hold the handrails when initially walking or running on the treadmill, until you are familiar with the use of the treadmill.
10. The treadmill is for indoors, do not use outdoors. Position the treadmill on a clean, level surface.
Note: The treadmill is made with specialised equipment, please do not attempt to modify any of the original parts.
11. The power cord of the motorised treadmill is specialised. If the power cord is damaged, please purchase it from distributor or contact our company directly.
12. If the treadmill should suddenly increase in speed due to an electronics failure or the speed inadvertently increased, the treadmill will come to a sudden stop when the pull pin is disengaged from the console.
13. Do not use an extension cord with this product. Keep the power cord clear from all moving parts. Do not place the power cord underneath the treadmill as it may become entangled and cause a serious safety risk. Ensure that the power cord is not near any high temperature.
14. When the treadmill is not being used, the power cord should be unplugged and the safety pull pin removed.
Note: The power cord of motorised treadmill made by special equipment, and if it is broken, please contact distributor quickly.
15. The treadmill is for home use only.
16. The treadmill maximum user weight is **100KG**.
17. Please do not overuse the treadmill so you can avoid any injury and do not use incorrect way for your safety.
18. When the treadmill is not being used, please keep the safety pull pin in the safety place to avoid the other use.

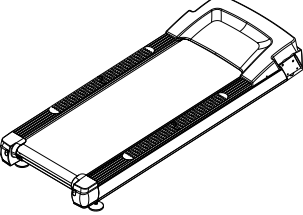
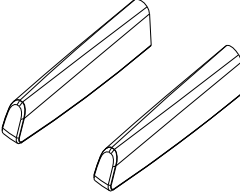
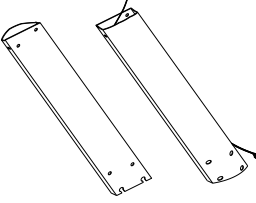
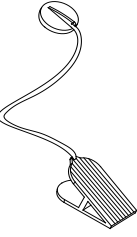
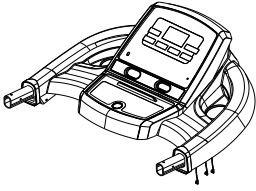
Assembly instruction

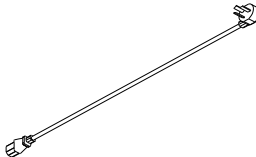
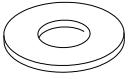
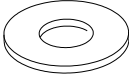
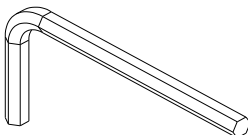
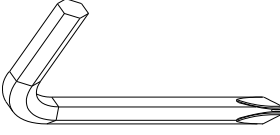
WHEN YOU OPEN THE CARTON, YOU WILL FIND THE BELOW SPARE PARTS:

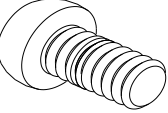
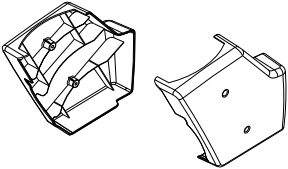
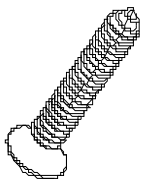
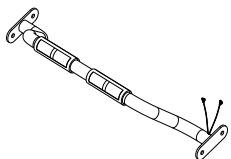
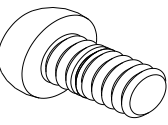
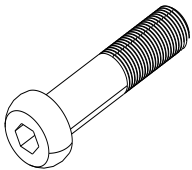
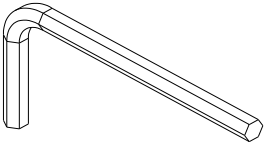
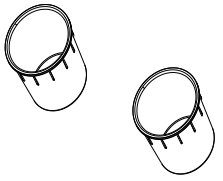
| | | | |
|---|---|--|---|
| <p>A1 Main frame 1set</p>  | <p>D50L/ R Left/ Right PU handle bar 1 set</p>  | <p>A3L/R Left / Right Upright 1 set</p>  | <p>C13 Safety key 1 set</p>  |
| <p>Console set 1 set</p>  | <p>C19 MP3 cord 1 pc</p>  | <p>C15 power lead 1 pc</p>  | <p>D21 Flat Washer M10 14 pcs</p>  |
| <p>D23 Washer M8 6 pcs</p>  | <p>D3 Allen wrench T5 1 pc</p>  | <p>D2 Allen wrench T6 1 pc</p>  | <p>B18 Silicon oil 1 pc</p>  |
| <p>D31 Round hex bolt M8*20 6 pcs</p>  | <p>B22/B23 Left/ Right motor side cover 1 set</p>  | <p>D48 Cross self-tapping bolt ST4.2*19 4 pcs</p>  | <p>A4A Cross bar 1 pc</p>  |
| <p>D105 Round hex bolt M10*20 6 pcs</p>  | <p>D11 Round head hex bolt M10*50 8 pcs</p>  | <p>D109 Allen wrench T8 1 pc</p>  | <p>B49 Water bottle 2 pcs</p>  |

STEP 1: Connect the Lower Wire (C17) of main frame and Middle Wire (C18) of right upright, then secure Right/Left Upright (A3L/R) with Round Head Hex Bolt M10*50 (D11) and Flat Washer M10 (D21). (Do not secure tight)

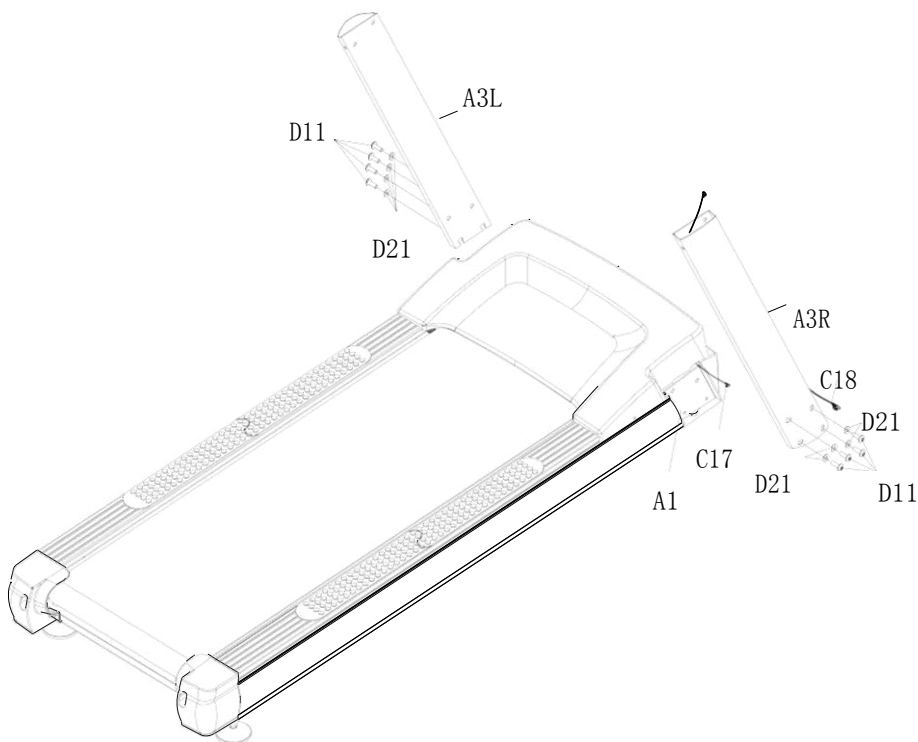

Step 2: Use Round Hex Bolt M8*20 (D31) to secure Left/Right PU Hand Rail (B50L/R).

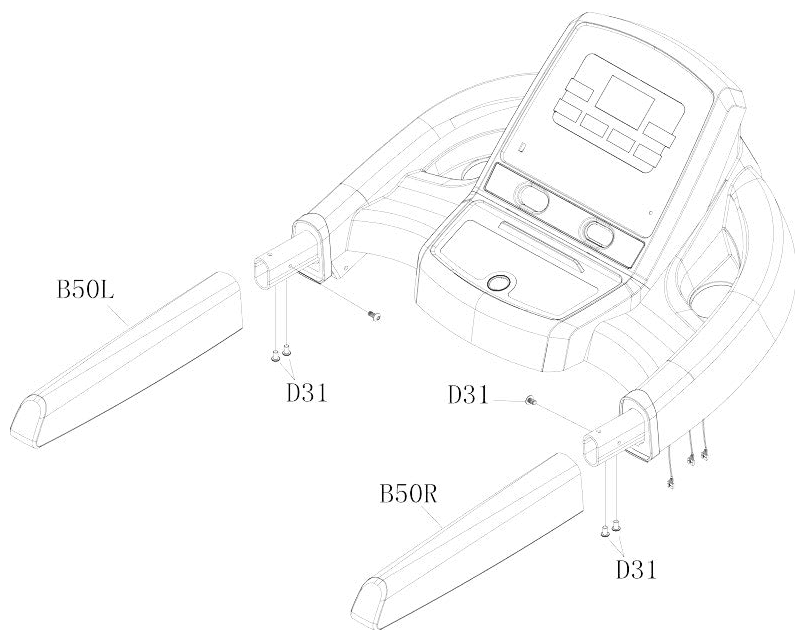

Step 3: Connect the Upper Cables (C16) of console and Middle Cable (C18) of right upright then tighten console with Left/Right Upright (A3L/R), then secure Left/Right upright (A3L/R) and Cross bar (A4A) with Round Hex Bolt M10*20 (D105) and Flat Washer M10 (D21). Secure all screws on uprights.

Last, connect the Pulse Upper Line (C39) and Pulse Bottom Line (C40)

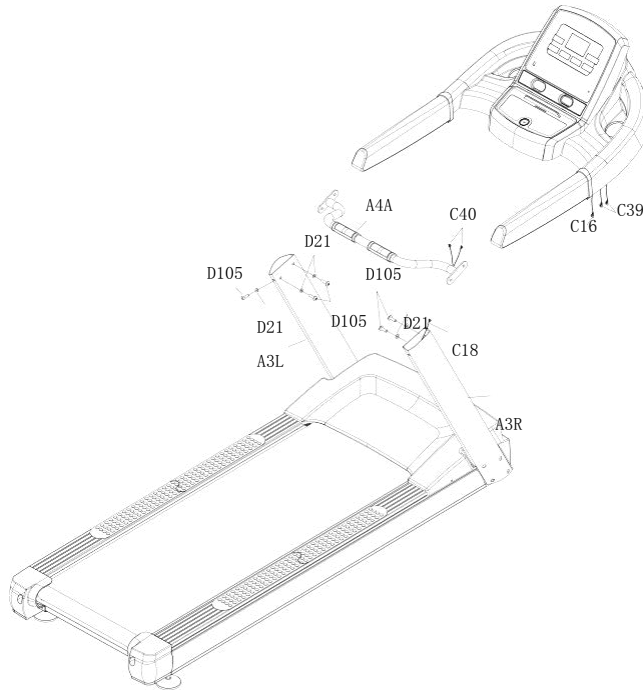

Step 4: Use Cross Self-tapping Bolt ST4.2*19 (D48) to secure Left/Right Motor Side Cover (B22/23) to Left/Right Upright (A3L/R). Put on Safety Key (C13), MP3 Line (C19), Water Bottle Holder (B49) and Power Cable (C15).

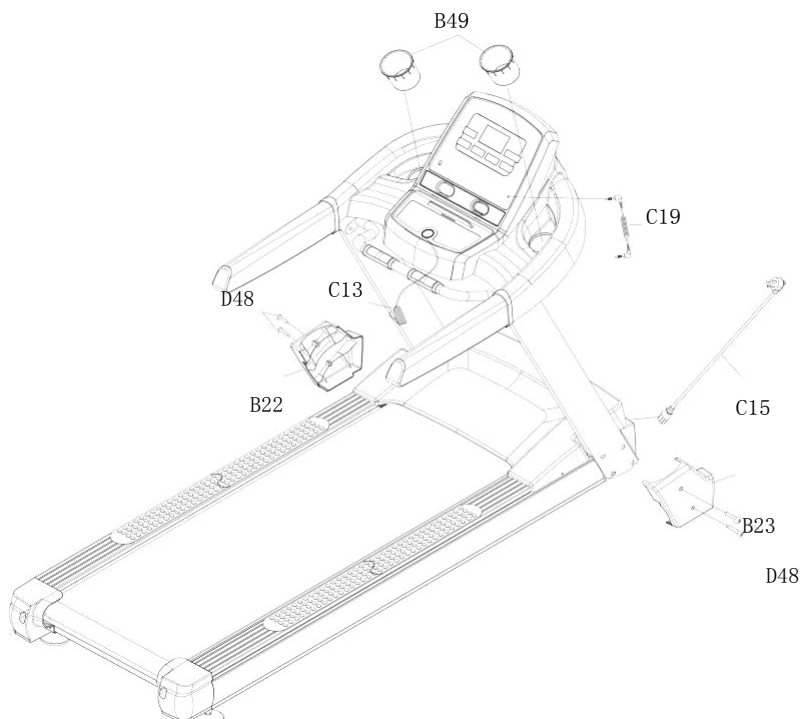

Grounding Methods

This product must be grounded. If it should malfunction or breakdown, grounding provides a path of least resistance for electric current to reduce the risk of electric shock. This product is equipped with a cord having an equipment-grounding conductor and a grounding plug. The plug must be plugged into an appropriate outlet that is properly installed and grounded in accordance with all local codes and ordinances.

DANGER – Improper connection of the equipment-grounding conductor can result in a risk of electric shock. Check with a qualified electrician or serviceman if you are in doubt as to whether the product is properly grounded. Do not modify the plug provided with the product – if it will not fit the outlet, please find a proper outlet installed by a qualified electrician.

This product is for use on a nominal 240V circuit and has a grounding plug. Make that the product is connected to an outlet having the same configuration as the plug. No adapter should be used with this product.

Operation Guide

1.1. WINDOW DISPLAY

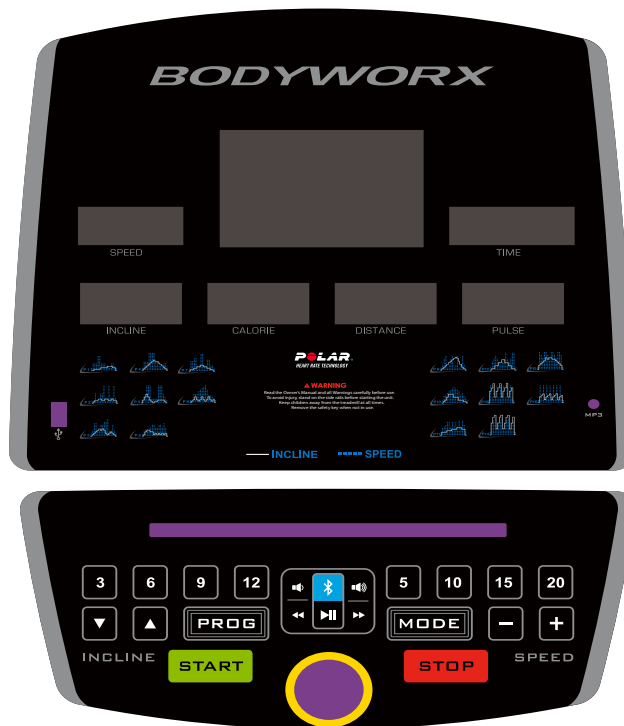

1.2. START

Normal start after 5 seconds countdown

1.3 PROGRAM

3 Countdown Mode, 16 Pre-set programs, 3 Users, and 3 HRC programs

1.4 SAFETY LOCK FUNCTION

The window shows "---" when you take away the safety key and the treadmill will stop quickly with "bibi"alarm noise. And put the safety key on, the computer will display for 2 seconds and the date countdown to "0"

1.5 BUTTON FUNCTION

1.5.1 START/STOP

“START”-- When the treadmill is not running, press this button to start, speed is “0.8”

“STOP”-- When the treadmill is running, press this button to stop, then set program default and then return to manual mode after stopped.

1.5.2 PROGRAM” BUTTON

When the treadmill is not running, press this button to choose from manual mode to pre-set mode P1-P16, body fat program, 3 countdown functions, U1-U3.

1.5.3 “MODE” BUTTON

When the treadmill is not running, press this button to choose countdown modes: “H-1”, “H-2”, “H-3”; “H-1” is the time countdown mode, and “H-2” is the distance countdown mode, “H-3” is the calorie countdown mode; press the “SPEED+/-” or “INCLINE+/-” button to adjust the data. After that, press the “START” button to start this treadmill.

1.5.4 “SPEED +/-” BUTTON

SPEED +/-, adjust speed when treadmill start, the increment is 0.1km/time in kilometre. Press the button for more than 2 seconds, and it will go up or down automatically.

1.5.5 SPEED QUICK BUTTON

Press the speed quick button 5km/h, 10km/h, 15km/h, 20km/h to adjust the speed directly when the treadmill is running.

1.5.6 “INCLINE+/-” BUTTON

INCLINE +/-, adjust incline when treadmill start; the increment is 1 level/time. Press the button for more than 2 seconds, and it will go up or down automatically

1.5.7 “INCLINE” QUICK BUTTON

Press the incline quick button 3, 6, 9, 12 to adjust the incline directly when the treadmill is running

1.6 DISPLAY FUNCTION

1.6.1 SPEED

Display running speed

1.6.2 TIME

Display the running time or countdown time

1.6.3 DISTANCE

Display the running total distance or distance countdown.

1.6.4 CALORIE

Display the calorie or calorie countdown

1.6.5 INCLINE

Display the incline

1.6.6 PULSE

Display pulse data

1.6.7 ALL WINDOW DISPLAY DATA RANGE

TIME: 0:00 – 99.59 (MIN)

DISTANCE: 0.00 – 99.9 (KM)

CALORIES: 0.0 – 999 (C)

SPEED: 0.8-22.0 (KM/H)

PULSE: 50 – 200 (BPM)

INCLINE: 0 – 15%

1.7 PULSE FUNCTION

When the treadmill is running, hold the hand pulse for about 5 seconds, it will display pulse data. The pulse data range is 50-200 times/minute. It has heart-shaped graphics when testing pulse. This data is only for reference, cannot be used for medical data.

1.8 PROGRAM EXERCISE CHART

| MODE \ TIME | | SET TIME / 16= EVERY GRADE TIME | | | | | | | | | | | | | | | |
|-------------|---------|---------------------------------|----|----|----|----|----|----|----|----|----|----|----|----|----|----|----|
| | | 1 | 2 | 3 | 4 | 5 | 6 | 7 | 8 | 9 | 10 | 11 | 12 | 13 | 14 | 15 | 16 |
| P1 | SPEED | 5 | 8 | 8 | 8 | 13 | 13 | 8 | 8 | 8 | 6 | 6 | 5 | 8 | 8 | 5 | 6 |
| | INCLINE | 0 | 0 | 3 | 3 | 3 | 3 | 4 | 4 | 4 | 4 | 5 | 5 | 5 | 4 | 4 | 0 |
| P2 | SPEED | 5 | 5 | 10 | 5 | 5 | 10 | 10 | 15 | 7 | 7 | 15 | 7 | 7 | 15 | 7 | 5 |
| | INCLINE | 0 | 3 | 4 | 4 | 5 | 5 | 4 | 4 | 5 | 5 | 4 | 4 | 5 | 4 | 4 | 0 |
| P3 | SPEED | 5 | 7 | 12 | 12 | 7 | 7 | 11 | 11 | 13 | 13 | 15 | 7 | 7 | 11 | 7 | 5 |
| | INCLINE | 0 | 3 | 4 | 5 | 6 | 7 | 6 | 7 | 6 | 4 | 3 | 4 | 5 | 4 | 3 | 0 |
| P4 | SPEED | 5 | 9 | 9 | 9 | 15 | 15 | 15 | 15 | 9 | 9 | 6 | 6 | 6 | 8 | 8 | 5 |
| | INCLINE | 0 | 3 | 6 | 5 | 6 | 7 | 8 | 9 | 8 | 8 | 7 | 6 | 5 | 4 | 3 | 0 |
| P5 | SPEED | 5 | 7 | 9 | 15 | 15 | 15 | 6 | 6 | 6 | 6 | 15 | 15 | 15 | 9 | 7 | 5 |
| | INCLINE | 0 | 5 | 7 | 9 | 7 | 5 | 4 | 0 | 4 | 4 | 5 | 5 | 5 | 5 | 6 | 0 |
| P6 | SPEED | 5 | 7 | 8 | 8 | 9 | 9 | 11 | 11 | 9 | 9 | 11 | 11 | 9 | 12 | 9 | 5 |
| | INCLINE | 0 | 3 | 5 | 6 | 6 | 5 | 5 | 3 | 4 | 3 | 4 | 3 | 4 | 3 | 4 | 0 |
| P7 | SPEED | 5 | 10 | 10 | 12 | 12 | 7 | 7 | 15 | 15 | 7 | 7 | 11 | 11 | 7 | 7 | 5 |
| | INCLINE | 0 | 3 | 3 | 4 | 4 | 5 | 5 | 6 | 6 | 5 | 5 | 4 | 4 | 3 | 3 | 0 |
| P8 | SPEED | 5 | 5 | 9 | 9 | 9 | 11 | 12 | 13 | 14 | 15 | 12 | 8 | 8 | 8 | 6 | 5 |
| | INCLINE | 0 | 3 | 4 | 6 | 4 | 3 | 4 | 6 | 4 | 3 | 4 | 6 | 4 | 3 | 4 | 0 |
| P9 | SPEED | 5 | 7 | 11 | 13 | 5 | 7 | 11 | 13 | 5 | 7 | 13 | 5 | 7 | 13 | 7 | 5 |
| | INCLINE | 0 | 3 | 4 | 5 | 6 | 7 | 8 | 9 | 10 | 11 | 10 | 8 | 6 | 4 | 3 | 0 |
| P10 | SPEED | 5 | 8 | 9 | 10 | 11 | 12 | 13 | 14 | 13 | 12 | 10 | 9 | 10 | 8 | 7 | 5 |
| | INCLINE | 0 | 3 | 4 | 6 | 8 | 8 | 8 | 6 | 6 | 6 | 4 | 4 | 4 | 3 | 3 | 0 |
| P11 | SPEED | 5 | 8 | 11 | 10 | 12 | 12 | 9 | 12 | 9 | 12 | 9 | 13 | 9 | 13 | 10 | 5 |
| | INCLINE | 0 | 4 | 4 | 4 | 5 | 5 | 5 | 6 | 6 | 6 | 7 | 7 | 7 | 6 | 6 | 0 |
| P12 | SPEED | 5 | 9 | 11 | 13 | 11 | 9 | 7 | 9 | 11 | 15 | 11 | 9 | 11 | 15 | 15 | 5 |
| | INCLINE | 0 | 3 | 3 | 5 | 5 | 7 | 7 | 9 | 9 | 7 | 7 | 5 | 5 | 3 | 3 | 0 |
| P13 | SPEED | 5 | 15 | 7 | 15 | 7 | 15 | 7 | 15 | 7 | 15 | 7 | 15 | 7 | 15 | 7 | 5 |

| | | | | | | | | | | | | | | | | | |
|------------|----------------|---|----|----|----|----|----|----|----|----|----|----|----|----|----|----|---|
| | INCLINE | 0 | 10 | 12 | 15 | 6 | 10 | 12 | 15 | 6 | 10 | 12 | 15 | 6 | 10 | 12 | 0 |
| P14 | SPEED | 5 | 11 | 13 | 15 | 7 | 11 | 13 | 15 | 7 | 11 | 13 | 15 | 7 | 11 | 13 | 5 |
| | INCLINE | 0 | 10 | 14 | 15 | 6 | 10 | 14 | 15 | 6 | 10 | 14 | 15 | 6 | 10 | 14 | 0 |
| P15 | SPEED | 5 | 15 | 13 | 11 | 15 | 15 | 13 | 11 | 15 | 15 | 13 | 11 | 15 | 15 | 13 | 5 |
| | INCLINE | 0 | 5 | 6 | 7 | 8 | 10 | 9 | 10 | 10 | 9 | 9 | 8 | 7 | 6 | 5 | 0 |
| P16 | SPEED | 5 | 15 | 7 | 15 | 7 | 15 | 7 | 15 | 7 | 15 | 7 | 15 | 7 | 15 | 7 | 5 |
| | INCLINE | 0 | 6 | 7 | 8 | 4 | 6 | 7 | 8 | 4 | 6 | 7 | 8 | 4 | 6 | 7 | 0 |

1.9 MANUAL MODEL OPERATION

1.9.1 Press START key, time count down 5 seconds, then treadmill will start to work with initial speed 1km/h.

1.9.2 Press SPEED +/-, you can adjust the speed.

1.9.3 Press INCLINE +/-, you can adjust the incline.

1.9.4 Press STOP, you can stop treadmill at working state.

1.9.5 Press QUICK SPEED key, you can quickly adjust the speed you want.

1.9.6 Press QUICK INCLINE key, you can quickly adjust the incline you want.

1.10 3 COUNTDOWN FUNCTION PARAMETER DATA

Countdown time initial setting 30:00 minutes, setting range 5:00---99:00 minutes, each step 1:00.

Countdown calorie initial setting 50 term, setting range 10---990 term, each step 10.

Countdown distance initial setting 1.0 km, setting range 0.5---99.9 km, each step 0.1

Cycle switch order is: manual, time, distance, calories.

1.11 BODY TESTER (FAT)

At the beginning, press "PROGRAM" continually to enter "FAT" body fat test, window display "FAT".

Press "MODE" to enter (F1 SEX, F2 AGE, F3 HEIGHT, F4 WEIGHT). Press "SPEED +", "SPEED -" to set. After setting, the computer will display F5 and grasp the hand pulse, the window will display your body quality index.

The body quality index is to test the relation between height and weight not the body scale.

The body fat suits any male and female to adjust the weight according together with other body quality index. The ideal FAT should be between 20-25, if under 19, it means too thin. If between 25 and 29, it means overweight, if over 30, it means obesity. (The data is just for reference and cannot be used as medical data).

1 Sex: 01 Male 02 Female

2 Age: 10--99

| | | |
|---|-----------------|---------------|
| 3 | Height: | 100--220 |
| 4 | Weight: | 20--150 |
| 5 | FAT \leq 19: | Under weight |
| | FAT= (20---25): | Normal weight |
| | FAT= (25---29): | Over weight |
| | FAT \geq 30: | Obesity |

1.12 USER PROGRAM

Besides 15 pre-set programs, there are 3 user-defined programs: U1, U2 and U3. Each user program has 10 segments. The user can set the desired speed and incline. Press "PROGRAM" button to choose U1, U2 or U3, press "MODE" button to enter setting condition, then set the time of the first segment. Press "SPEED+" and "SPEED-" to set speed. Press "INCLINE+" and "INCLINE-" to set incline. Press "MODE" button and your choice will be set. The next workout segment will flash, go through the same setup as you completed with segment one. You must complete all 10 segments and then your user program is ready to use. Press "STOP" key to return to last segment setting any time.

1.13 HRC PROGRAM

There are 3 HRC programs (HRC1-HRC3) in total.

The parameter data setting order is "AGE" -> "THE (HRC) data" -> "TIME".

HRC: Detect user's actual heart rate through wireless receiver and set different heart rate data as a goal to adjust speed and incline during running time.

It's recommended that user utilise the wireless chest belt while running HRC function.

1.13.1 After turning on the power, press "PROG" key to choose HRC function. HRC function is turned on when "HRC" characters shown on the screen.

User can use "SPEED +/-" to adjust age (data from 13 to 80) after seeing the "30" shown on the screen.

1.13.2 Press "MODE" key to enter the setting of heart rate. The standard heart rate is fixed at different data from HRC1 to HRC3. Heart rate data can be adjusted from 50 to 200. User can use "SPEED +/-" to adjust the data. (It's recommended that standard heart rate data doesn't need to be changed for physical health condition).

FORMULA IS CALCULATED AS BELOW:

HRC1 is T.H.R = $(220 - \text{age}) \times 60\%$,

HRC2 is T.H.R = $(220 - \text{age}) \times 70\%$,

HRC3 is T.H.R = $(220 - \text{age}) \times 80\%$.

After finishing the setting of HRC data, user can press “MODE” key to modify the time. When “TIME” window flashes, it displays the default time as 30:00 minutes, and user can press “SPEED+/-” to set up time.

1.13.3 Enter “START” key to begin the workout (remember only can press “START” key after all setting is completed).

It's suggested that user utilise wireless chest belt to detect the heart rate. If the chest belt and hand pulse are used at the same time, the data from chest belt will show up only on the screen.

1.13.4 During the operating of HRC, the SPEED and INCLINE will adjust as below:

(1) If TARGET HEART RATE is $< \text{THR} - 15$, then the speed and incline will adjust automatically every 15 second, the SPEED will increase 0.8km/h and INCLINE add 1 section until they reach the maximum data.

(2) If $\text{THR} - 5 > \text{TARGET HEART RATE} \geq \text{THR} - 15$, then the speed and incline will adjust automatically every 15 second, the SPEED will increase 0.4km/h and INCLINE add 1 section until they reach the maximum data.

(3) If $\text{THR} + 5 \geq \text{TARGET HEART RATE} \geq \text{THR} - 5$, then the speed and incline will not change.

(4) If $\text{THR} + 15 \geq \text{TARGET HEART RATE} \geq \text{THR} + 5$, then the speed will adjust automatically every 15 second, the SPEED will decrease 0.4km/h and INCLINE less 1 section until they reach the minimum data.

(5) If TARGET HEART RATE is $\geq \text{THR} + 15$, then the SPEED and INCLINE will adjust automatically every 15 second, the SPEED will decrease 0.8km/h and INCLINE less 2 sections until they reach the minimum data.

1.14 BLUETOOTH MUSIC FUNCTION

Bluetooth Music Function: Press the “Bluetooth” key till the display shows Bluetooth icon, turn on the Bluetooth of your device to match with the computer and play the music, user can increase or decrease the volume from the device and also can turn back to last song or jump to next song.

1.15 OTHERS

1.15.1 The system will enter into power saving mode automatically if there is no any action within 10 minutes under IDLE MODE and there is no display and backlit on the computer. Press any key to resume the system.

1.15.2 Countdown time, countdown calorie and countdown distance, you just can set one of them at one time, press last item to set running, the setting parameter is countdown, others display normal data

1.15.3 MP3 audio function: Insert the MP3 line in the input hole of the right side in the computer.

1.15.4 On display – Distance covered, Calories burnt, Pulse reading, Body Fat test shown is only for indicative purpose and may vary from machine to machine. Do not compare these readings to a medical instrument.

Getting started guide

PREPARE

If you are over 35 years old, or have health problems or if this is your first time doing fitness exercise, please consult a doctor or professional before use.

Before you exercise, please stand on the side to learn how to operate, such as start, stop and speed adjustments. After that stand on the plastic deck of the treadmill board, and hold the handrail. Start with 1.6--3.2 km/h low speed, stand straight, look forward, and start moving your feet a few times, then stand on the belt to exercise. After adapting, you can adjust the speed to 3--5 km/h and keep doing this for about 10 minutes, then stop.

EXERCISE

Start exercise by walking slowly. Remember it is for your health and if you feel uncomfortable stop exercising immediately and seek medical advice.

AMOUNT OF EXERCISE

SHORTCUT—The best way to save time is do 15-20 minutes exercise.

If you are finding it difficult to increase your exercise intensity by increasing the speed, you can alternatively choose to increase the incline slowly which will also increase the exercise intensity for you.

EXERCISE FREQUENCY

It is better to make a weekly time schedule for your exercise routine to ensure it forms part of your busy schedule.

Safety Exercise

Please consult a professional staff before you exercise. He can help recommend exercise rate/intensity and time according to your age and health condition. When running, if you feel your chest tightness or any chest pain, irregular heartbeats, short of breath, any dizziness or are unwell, please STOP IMMEDIATELY! Please consult a professional staff before you want to continue to exercise. If you regularly use treadmill, you can choose normal walk speed or jog speed.

If you have no experience or cannot make sure of the best testing speed, you can reference below the standards:

| | |
|-------------------|-----------------------------------|
| Speed 1-3.0 km | Frail and elderly people. |
| Speed 3.0-4.5 km | People who do not exercise often. |
| Speed 4.5-6.0 km | Quick walkers. |
| Speed 6.0-7.5 km | Fast walkers. |
| Speed 7.5-9.0 km | Jogger. |
| Speed 9.0-12.0 km | Intermediate speed runner. |
| More than 12.0 km | Excellent runner. |

ATTENTION: It is suitable for walker to choose less than or equal to 6km speed.

Warm-up Exercise

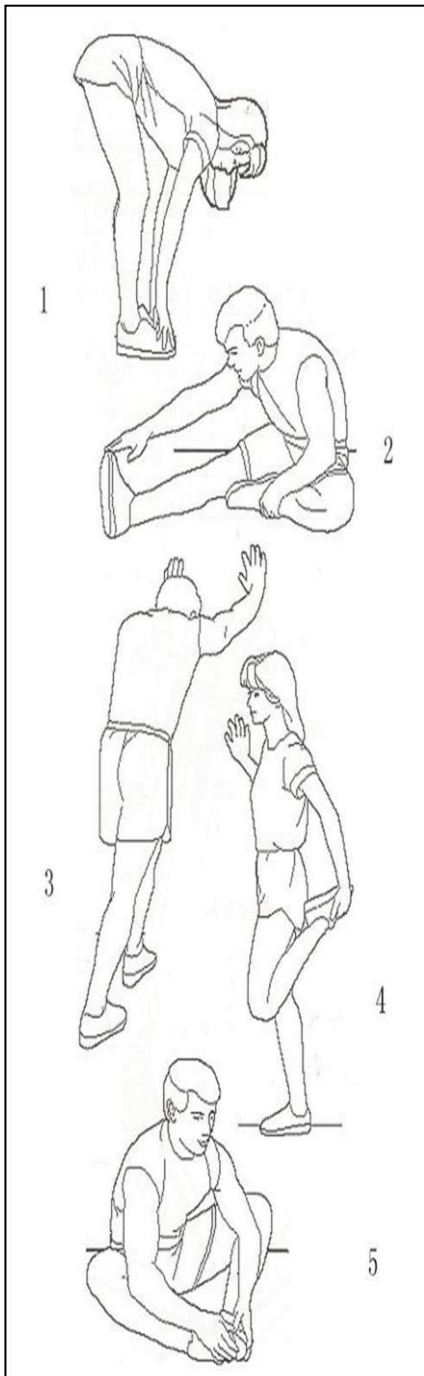

It is best to do some warm-up before exercising. Warm the muscles with easy stretches for 5 to 10 mins to warm-up. Then stop and according to below method to do stretch exercise for 5 times, each foot for 10 seconds or more every time. After running, do these stretch exercises again.

- 1. Reach Down:** Knees slightly bent and body slowly bent forward, back and shoulders relax, trying to touch your toes. Hold for 10 to 15 seconds and relax. Repeat 3 times (See picture 1).
- 2. Hamstrings Stretches:** Sitting on a clean cushion, put one leg straight, the other inward and close to the inside of the straight leg. Try to touch your toes with your hands. Hold for for 10 to 15 seconds and relax. Repeat 3 times for each leg (See picture 2).
- 3. Calf and Feet Tendon Stretches:** Standing with two hands on the wall or tree, one leg behind. Keeping your legs straight and the heel on the ground, tilt towards the wall. Hold for 10 to 15 seconds and relax. Repeat 3 times for each leg (See picture 3).
- 4. Quadriceps Stretches:** Keeping your balance with your left hand holding on the wall or table, then stretch your right heel towards your buttocks slowly, until you feel very tense in the front of your thigh. Hold for 10 to 15 seconds and relax. Repeat 3 times for each leg (See picture 4).
- 5. Sartorius (inner muscles of the thigh muscle) Stretches:** Sitting down with your soles opposite and knees outward, pull your feet toward your groin, hold for 10 to 15 seconds, and relax. Repeat 3 times (See picture 5).

Maintenance Instruction

WARNING: Please make sure you pull out the treadmill's power plug before cleaning or maintaining the product.

CLEANING: General cleaning of the unit will greatly prolong the treadmill's life.

Keep treadmill clean by dusting regularly. Be sure to clean the exposed part of the deck on either side of the walking belt and also the side rails. This reduces the build-up of foreign material underneath the walking belt. Make sure the shoes are clean. The top of the belt may be cleaned with a wet soapy cloth. Be careful to keep liquid away from inside the motorised treadmill frame or from underneath the belt.

WARNING: Always unplug the treadmill from the electrical outlet before removing the motor cover.

At least once a year remove the motor cover and vacuum under the motor cover.

This treadmill's walking belt and deck are equipped with a pre-lubricated, low maintenance deck system. The belt/deck friction may play a major role in the function and life of your treadmill, thus requiring periodic lubrication. We recommend a periodic inspection of the deck.

We recommend lubrication of the deck according to the following timetable:

| | |
|--------------------------------------|---------------|
| Light user (less than 3 hours/ week) | Every 60 days |
| Medium user (3-5 hours/ week) | Every 45 days |
| Heavy user (more than 5 hours/ week) | Every 30 days |

We suggest you buy lubricating oil from local distributors.

Pay attention, and for any other maintenance, please ask professionals for help.

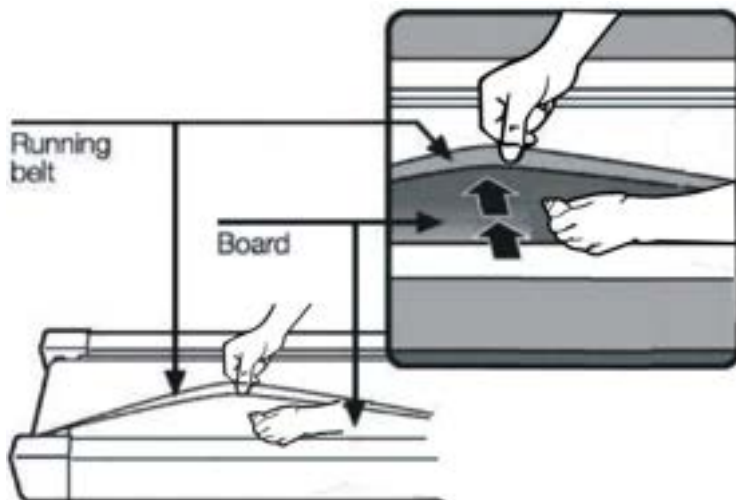

Belt Adjustment

Place treadmill on a level surface. Make treadmill run at approximately 6-8 km/h, observe the running belt deviation.

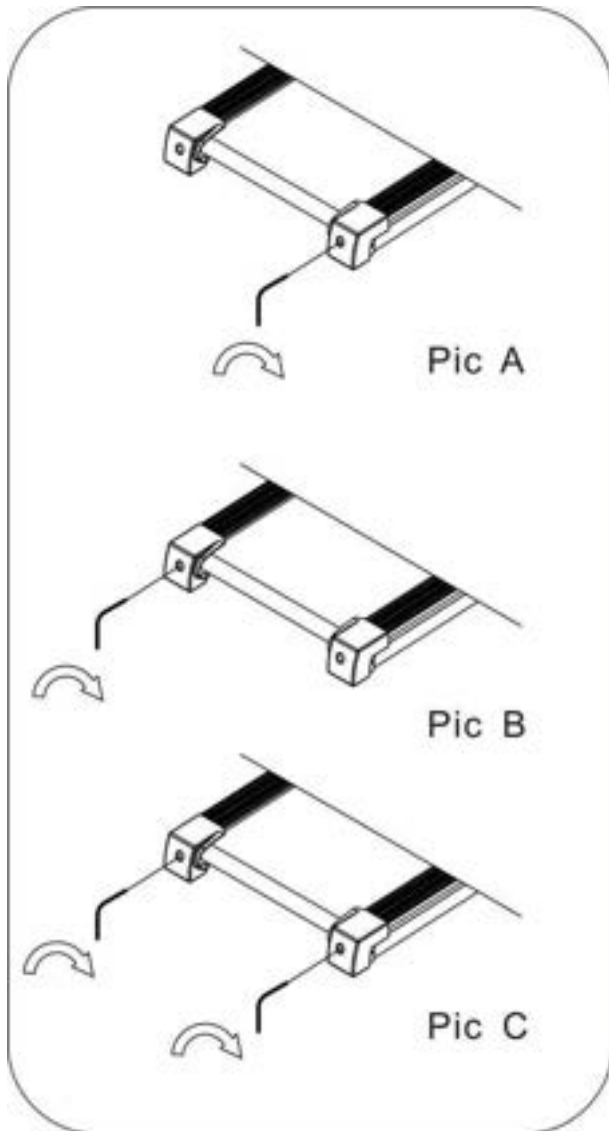

If the belt has drifted to the right, unplug the safety lock and power switch, and turn the right adjusting bolt 1/4 clockwise, then insert the power switch and safety lock. Turn on treadmill and observe the running belt deviation. Repeat above steps until the running belt is placed in the middle. **See picture A.**

If the treadmill belt is moving to the left, unplug the safety lock, turn off the power, then turn left adjusting bolt clockwise rotation 1/4 turn. Turn on the safety lock and power to have treadmill running, checking the deviation of the treadmill belt. Repeat the above steps until the belt is centered. **See picture B.**

The treadmill belt will gradually stretch after the above steps or after a period of use. Unplug the safety lock and turn off the power. Adjust left/right bolts clockwise rotation 1/4. Turn on the safety lock and power to have treadmill running, then standing on the belt to confirm the tightness.

Repeat the above steps until the belt has moderate tightness. **See picture C.**

EXPLODING DRAWING

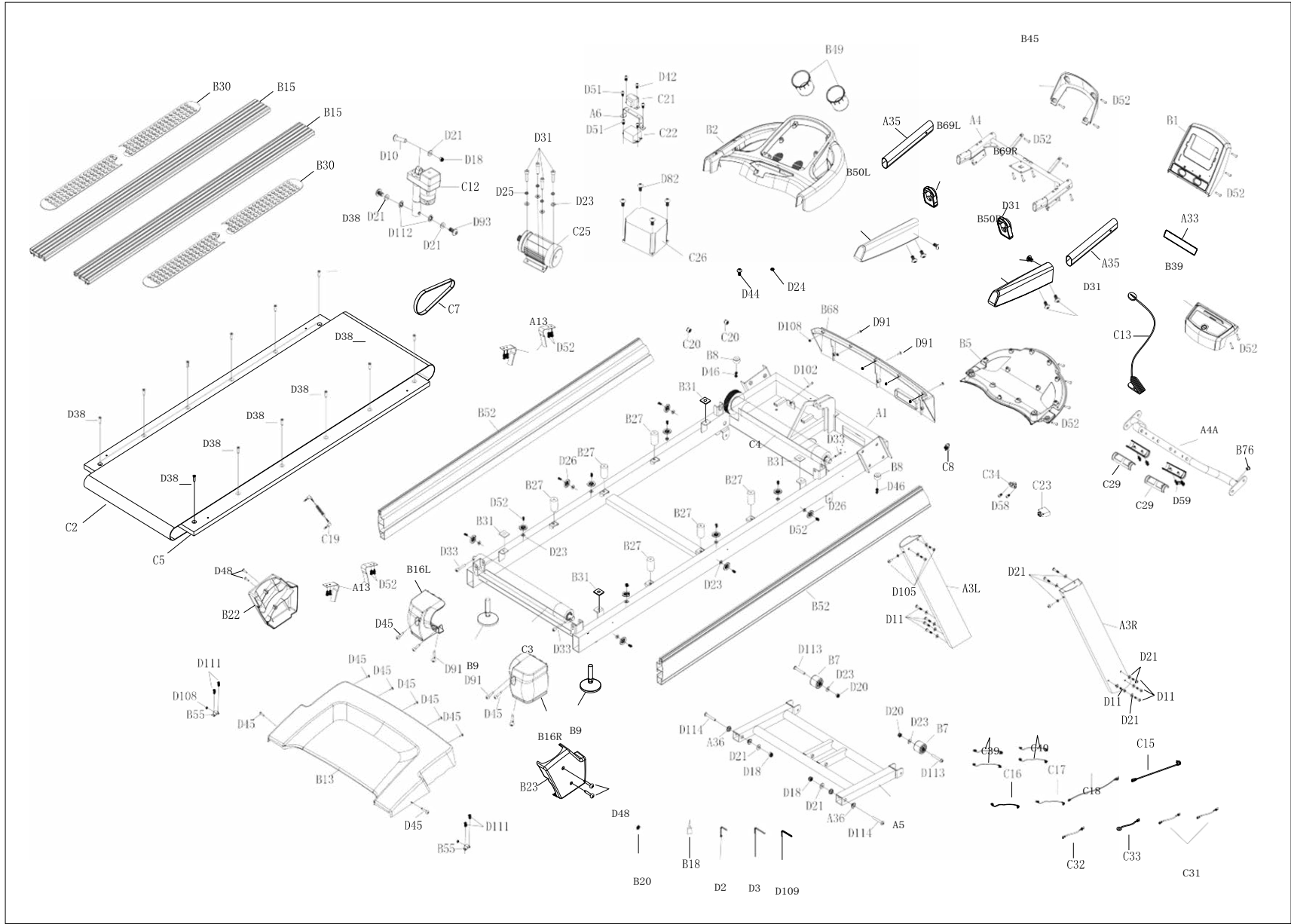

Parts list

| A. Frame parts | | | | | | |
|------------------------------------|----------------------|-----|--|-------|-----------------------------|-----|
| No. | Description | Qty | | No. | Description | Qty |
| A1 | Base frame | 1 | | A6 | Filter bracket | 1 |
| A3L | Left upright | 1 | | A13 | Belt guide | 4 |
| A3R | Right upright | 1 | | A33 | Speaker network | 1 |
| A4 | Handrail bracket | 1 | | A35 | Handrail tube | 2 |
| A4A | Cross bar | 1 | | A36 | Shaft | 4 |
| A5 | Incline frame | 1 | | | | |
| B. Plastic parts | | | | | | |
| No. | Description | Qty | | No. | Description | Qty |
| B1 | Console set | 1 | | B27 | New cushion | 6 |
| B1-1 | Overlay | 1 | | B30 | Non-slip sticker | 4 |
| B1-3 | Console panel | 1 | | B31 | Rubber pad | 4 |
| B2 | Console cover | 1 | | B39 | Bottom console | 1 |
| B5 | Console bottom cover | 1 | | B39-1 | Bottom overlay | 1 |
| B7 | Transport wheel | 2 | | B39-2 | Bottom membrane Key | 1 |
| B8 | Foot pad | 2 | | B39-3 | Bottom console cover | |
| B9 | Adjustable foot pad | 2 | | B45 | Console bottom cover | 1 |
| B13 | Motor upper cover | 1 | | B49 | Water bottle holder | 2 |
| B15 | Side rail | 2 | | B50L | Left PU handrail | 1 |
| B16L | Left end cap | 1 | | B50R | Right PU handrail | 1 |
| B16R | Right end cap | 1 | | B52 | Solid side rail | 2 |
| B18 | Silicon oil | 1 | | B55 | Motor plastic bracket | 2 |
| B20 | Round plug | 1 | | B68 | Motor front cover | 1 |
| B22 | Motor left cover | 1 | | B69L | Left handrail silicon ring | 1 |
| B23 | Motor right cover | 1 | | B69R | Right handrail silicon ring | 1 |
| C. Electric and drive parts | | | | | | |
| No. | Description | Qty | | No. | Description | Qty |
| C2 | Running belt | 1 | | C20 | Magnetic ring | 2 |

| | | | | | | |
|-----|--------------------|---|--|-----|--------------------------|---|
| C3 | Rear roller | 1 | | C21 | Inductance | 1 |
| C4 | Front roller | 1 | | C22 | Filter | 1 |
| C5 | Running board | 1 | | C23 | Overload protection | 1 |
| C7 | Motor belt | 1 | | C25 | AC motor | 1 |
| C8 | Power switch | 1 | | C26 | Inverter | 1 |
| C12 | Incline motor | 1 | | C29 | Pulse | 2 |
| C13 | Safety key | 1 | | C31 | Single line (brown) 150 | 2 |
| C15 | Power cable | 1 | | C32 | Single branch (blue) 150 | 1 |
| C16 | Console upper wire | 1 | | C33 | Single ground wire | 1 |
| C17 | Console lower wire | 1 | | C34 | Outlet | 1 |
| C18 | Middle cable | 1 | | C39 | Pulse upper line | 2 |
| C19 | MP3 line | 1 | | C40 | Pulse bottom line | 2 |

D. Hardware parts

| No. | Description | Qty | No. | Description | Qty |
|-----|-------------------------------|-----|------|----------------------------------|-----|
| D2 | Allen wrench T6 | 1 | D46 | Cross head bolt M5*20, washer | 2 |
| D3 | Allen wrench T5 | 1 | D48 | Cross self-tapping bolt ST4.2*19 | 4 |
| D10 | Round hex bolt M10*45 | 1 | D51 | Cross head bolt M5*8 | 4 |
| D11 | Round head hex bolt M10*50 | 8 | D52 | Cross self-tapping bolt ST4.2*16 | 40 |
| D18 | Nylon nut M10 | 3 | D58 | Cross self-tapping bolt ST3.5*16 | 2 |
| D20 | Nylon nut M8 | 2 | D59 | Cross self-tapping bolt ST2.9*19 | 4 |
| D21 | Flat washer M10 | 19 | D82 | Cross bolt M4*12 | 4 |
| D23 | Flat washer M8 | 18 | D91 | Cross head bolt ST4.2*20 | 11 |
| D24 | Spring washer M5 | 1 | D93 | Hex round head bolt M10*40 | 2 |
| D25 | Spring washer M8 | 4 | D102 | Hex anti-skid bolt M8*55 | 1 |
| D26 | Bowl washer | 12 | D105 | Round hex bolt M10*20 | 6 |
| D31 | Hex round head bolt M8*20 | 10 | D108 | Hex nut M5 | 7 |
| D33 | Hex round head bolt M8*55 | 3 | D109 | Allen wrench T8 | 1 |
| D38 | Cross head bolt M6*30 | 12 | D111 | Cross self-tapping bolt ST4.2*25 | 4 |
| D42 | Cross head bolt M4*10, washer | 2 | D112 | Inner washer M10 | 2 |
| D44 | Cross head bolt M5*12, washer | 3 | D113 | Round head hex bolt M8*65 | 2 |
| D45 | Cross head bolt M5*15, washer | 9 | D114 | Round head hex bolt M10*70 | 2 |

Error code and significance

| Error Code | Description | Solutions |
|------------------------|---|---|
| E1 | Failure communication between inverter and computer | <ol style="list-style-type: none"> 1. Check if computer is connected to inverter with correct wires, check connector, check if wire is damaged or unplug and re-connect. 2. Replace inverter and test. 3. Replace computer and test. |
| E2 | Inverter over heat | <ol style="list-style-type: none"> 1. Switch off for over 20 seconds and switch on again. If E2 persists. 2. Check if the fan and heat sink are clean or if the fan is working. If E2 persists. 3. Replace inverter. |
| E3 | Input voltage low | <ol style="list-style-type: none"> 1. Switch off for over 20 seconds and switch on again. If E3 persists. 2. Check if the input voltage low. If E3 persists. 3. Replace inverter. |
| E5 | Inverter over-current | <ol style="list-style-type: none"> 1. Switch off for over 20 seconds and switch on again. If E5 persists. 2. Check if roller bearings are stuffed and not rotating freely inside front and rear rollers, check if running belt and running deck are well lubricated without excessive wear and tear, check belt tension is moderate. If E5 persists. 3. Replace inverter. |
| E7 | Overload protection | <ol style="list-style-type: none"> 1. Switch off for over 20 seconds and switch on again. If E7 persists. 2. Check if roller bearings are stuffed and not rotating freely inside front and rear rollers, check if running belt and running deck are well lubricated without excessive wear and tear, check belt tension is moderate. If E7 persists. 3. Replace inverter. |
| E4 | Incline adjustment | <ol style="list-style-type: none"> 1. Check incline motor sensor wire if connect correctly, re-plug in. 2. Check incline motor AC cable if connected correctly, the incline AC cable is connecting correctly to follow the controller mark. 3. Check if the cable of motor is damage. 4. Replace cable or incline motor, then press the adjustment button to run again. |
| E6 | Other error of inverter | <ol style="list-style-type: none"> 1. Switch off for over 20 seconds and switch on again. If E6 persists. 2. Replace inverter. |
| — | Computer doesn't detect safety key signal | <ol style="list-style-type: none"> 1. Check if safety key switch works, connecting wire works, or magnet inside works. 2. Safety key is not placed correctly. 3. Safety key is damaged, check and replace. |
| No display on computer | | <ol style="list-style-type: none"> 1. Check if power cable is connected to machine or change to another power outlet. If power switch is in position, test it by switch ON/OFF. If the power switch is burned out, replace one and make sure there's power to machine. 2. Check cable connection between computer and inverter. 3. Replace inverter or computer. |

BODYWORX



**BODYWORX
JT8500 TREADMILL**

Model No: JT8500

To register your warranty, please go to

www.gpisports.com.au

DISTRIBUTED EXCLUSIVELY BY

GPI Sports & Fitness

275 Wellington Road

Mulgrave, VIC, 3170

Australia
